



Plug-In Solar Installation Instructions

Adjustable Ground Mount Kit

Plug-In Solar – Power Your Future
www.pluginsolar.co.uk

These installation instructions contain important information on safety matters and the installation of the Plug-In Solar kit. Please read this guide carefully to ensure safe installation and operation.

*Installations are undertaken at the customer's own risk. This Installation manual is to be used as a guide only, and your discretion must be used when installing the Plug-In Solar kit. You MUST follow the IET Wiring Regulations and consult a professional if you are in any doubt. Plug-In Solar takes no responsibility for incorrect installation of our kits.

TABLE OF CONTENTS

Tool Requirements	3
Component Guide	4
Safety Instructions	5
Warnings	6
Step by Step Plug-In Solar Installation Guide	
Adjustable Ground Mount Installation	7
Micro-Inverter Installation	10
Wiring The Solar To The Existing Mains Circuit	14
Isolation/Isolator Requirements	16
Placing Warning Labels	17
Inspecting, Testing and Commissioning	
Inspecting and Testing your Plug-In Solar Installation	18
Commissioning your Plug-In Solar Installation	19
Completing your Warranty Card	21
Appendix	
Appendix 1. Plug-In Solar Connection Unit – Wiring Diagram	22
Appendix 2. Example G83/2 SSEG Installation Commissioning Confirmation Form	23
Appendix 3. Example Electrical Schematic Diagram	24
Appendix 4. Troubleshooting APS Dual Micro-Inverters	25
Appendix 5. APS Warranty Document	26
Appendix 6. APS Warranty Card	29
Appendix 7. APS G83/2 SSEG Test Report Certificate	30
Appendix 8. Solar Panel Warranty Document	31
Appendix 9. Solar Panel MCS Certificate	35
Appendix 10. Ground Mount Warranty	37

TOOL REQUIREMENTS

8mm Socket Tool



6mm Hex (Allen) Key



13mm Spanner

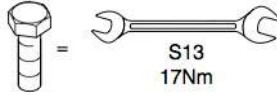

Drill with S8 Masonry Bit

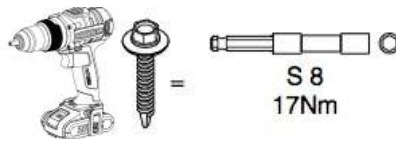

Voltage Tester



Wire Strippers

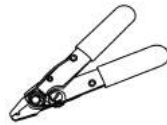

Flathead Screwdriver



Phillips Screwdriver



COMPONENT GUIDE

The number of components you receive will depend on the type of kit you have purchased. Please unpack all your items, and check you have all the correct components.

Solar Panel

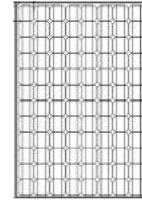

Adjustable Ground Mount System



Micro Inverter (Dual Input)

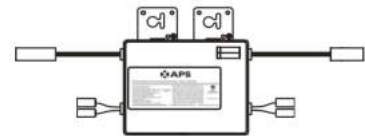

AC Bus (Trunk) Cable

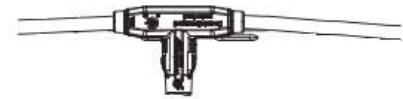

Trunk Cable Sealing Cap



End Cap

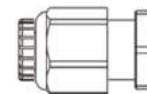

MC4 Sealing Caps (for kits with odd number of Solar Panels)

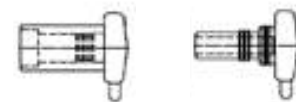

Plug-In Solar Connection Unit

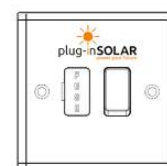

SAFETY INSTRUCTIONS

Before installing or using a Plug-In Solar kit, please read all instructions and cautionary markings in this document and on the Micro-Inverters and Solar Panels.

The installation of a Plug-In Solar kit shall be carried out by a competent person with sufficient skills and training to apply safe methods of work, in compliance with G83/2 Engineering Recommendations.

The installation of a Plug-In Solar kit will be carried out to no lower a standard than that required in the Manufacturer's installation instructions, as provided here.

No parameter relating to the electrical connection and subject to type verification certification will be modified unless previously agreed in writing between the DNO (Distribution Network Operator) and the Customer.

All electrical installations shall be performed in accordance with local electrical codes.

All appropriate health and safety regulations must be observed and required safety precautions taken.

Be aware that installation of this equipment includes the risk of electric shock.

Be aware that the body of the Micro-Inverter is the heat sink and can reach a temperature of 80°C. To reduce risk of burns, do not touch the body of the Micro-Inverter.

DO NOT disconnect the PV module from the Micro-Inverter without first disconnecting the AC power. In no circumstances, connect a DC input when an AC connector is unplugged.

DO NOT attempt to repair a Micro-Inverter. If it fails, contact APS Customer Support to obtain an RMA number and start the replacement process. Damaging or opening a Micro-Inverter will void the warranty.

CAUTION! The external protective earthing conductor is connected to the micro-inverter protective earthing terminal via an AC connector. When connecting; connect the AC connectors first to ensure the micro-inverter earthing then undertake the DC connections. When disconnecting; disconnect the AC by opening the branch circuit breaker. Whilst maintaining the protective earthing conductor in the branch circuit breaker, connect to the micro-inverter, then disconnect the DC inputs.

You MUST follow the IET Wiring Regulations at all times and consult a professional electrician if you are in any doubt.

WARNINGS

Never disconnect the DC wire connectors under load. Ensure that no current is flowing in the DC wires prior to disconnecting. An opaque covering may be used to cover the module prior to disconnecting the module.

Do not touch any live parts in the system, including the Solar array, when the system has been connected to the electrical grid.

Prior to installing any of the Micro-Inverters, verify that the utility voltage at the point of common connection matches the voltage rating on Micro-Inverter label.

Do not mount the Micro-Inverter in a location that allows exposure to direct sunlight. Allow a minimum of 3/4''(1.5cm.) between the roof and the bottom of the Micro-Inverter to allow proper airflow.

Always disconnect AC power before disconnecting the PV module wires from the Micro-Inverter. The AC connector of the first Micro-Inverter in a branch circuit is suitable, as a disconnecting means, once the AC branch circuit breaker in the load center has been opened.

The Micro-Inverter is powered by PV module DC power. Make sure you disconnect and reconnect the DC connections to watch for the three short flashes.

ADJUSTABLE GROUND MOUNT SYSTEM INSTALLATION

Important Notes before the installation of Adjustable Ground Mounts

1. The size of the mounting system (number of mounting triangles) should be specifically calculated for each individual project, following the specified structural engineering standards and regulations.
2. A prerequisite for proper application is a solid mounting base that can accommodate the occurring forces (weight, wind and snow loads).
3. You **MUST** ballast your mounting system, especially in high wind areas. This can be done with sandbags or similar (not supplied). For additional fixings to secure your grounds mounts to concrete/metal or other material please contact us.
4. The installation instructions of the solar panel manufacturers must be adhered to.
5. When installing this product please observe the appropriate health and safety regulations and take required safety precautions.

Plug-In Solar takes no responsibility for the method by which you choose to install your mounting system. This is a guide only. Please consult a roofing expert if you are in any doubt on how to safely and correctly install your system.

Adjustable Ground Mount System Components



Adjustable Mounts

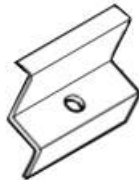

Solar Panel Clamps



SFS Screws



Bolts

Adjustable Ground Mount Installation

1. Open a mounting triangle, and pull adjustable arm upwards. You can choose the angle at which you install the panels for the best possible efficiency, by adjusting the support arm. You will need your 13mm Spanner at this stage.

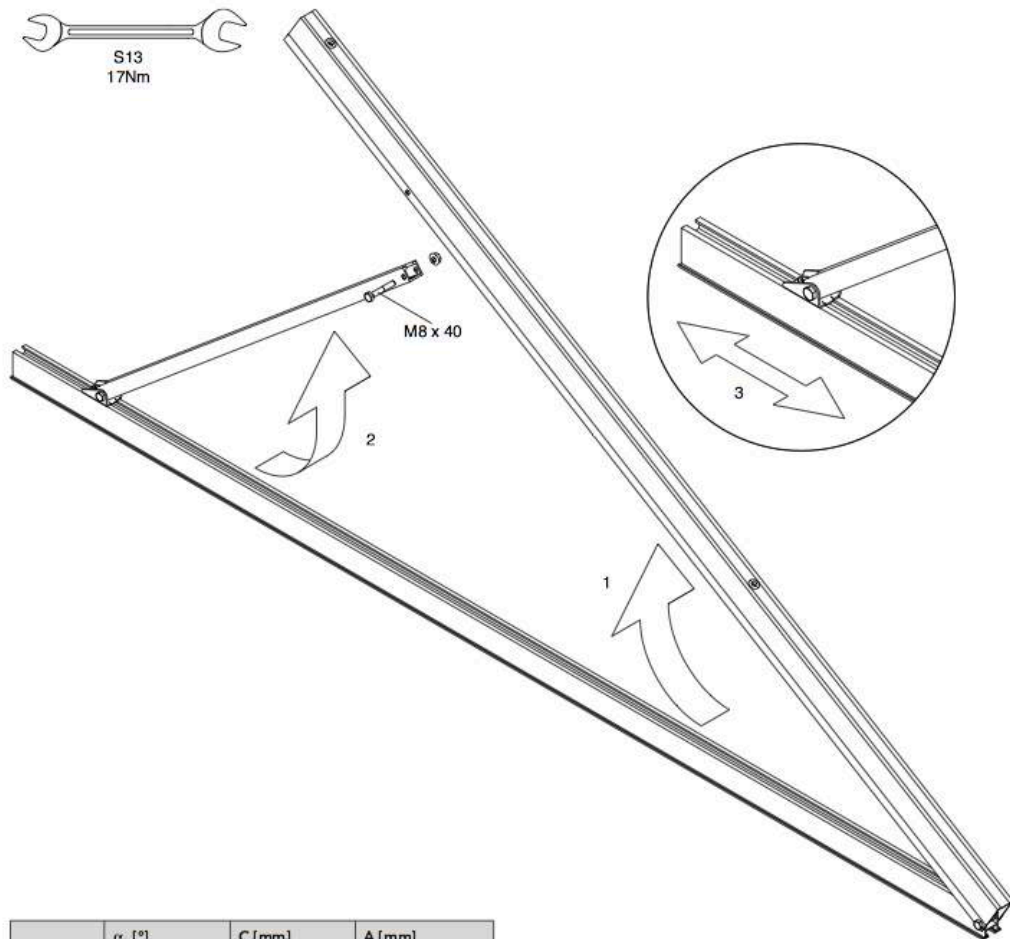

	α_1 [°]	C [mm]	A [mm]
TRIC F 15	10	168	500
	15	271	670
	20	464	820
TRIC F 30	25	105	970
	30	278	1.120
	35	525	1.250
TRIC F 45	40	89	1.378
	45	274	1.493
	50	486	1.597
	55	734	1.689
	60	1.071	1.768

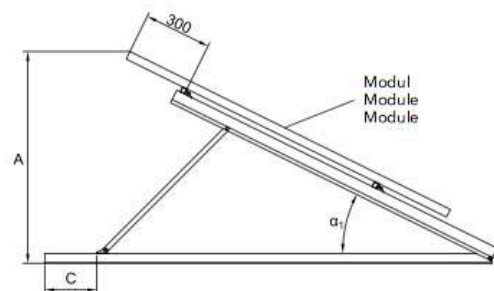

	α_2 [°]	C [mm]	A [mm]
TRIC F Quer	20	16	470
	25	79	550
	30	159	620
	35	261	690
	40	403	760

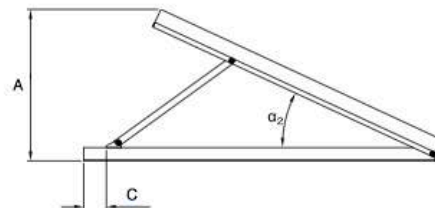

- Secure the Solar Panels to the Ground Mount system (using the nuts, bolts and SFS screws provided). You will need your Hex key, Spanner and a drill with a masonry bit at this stage.

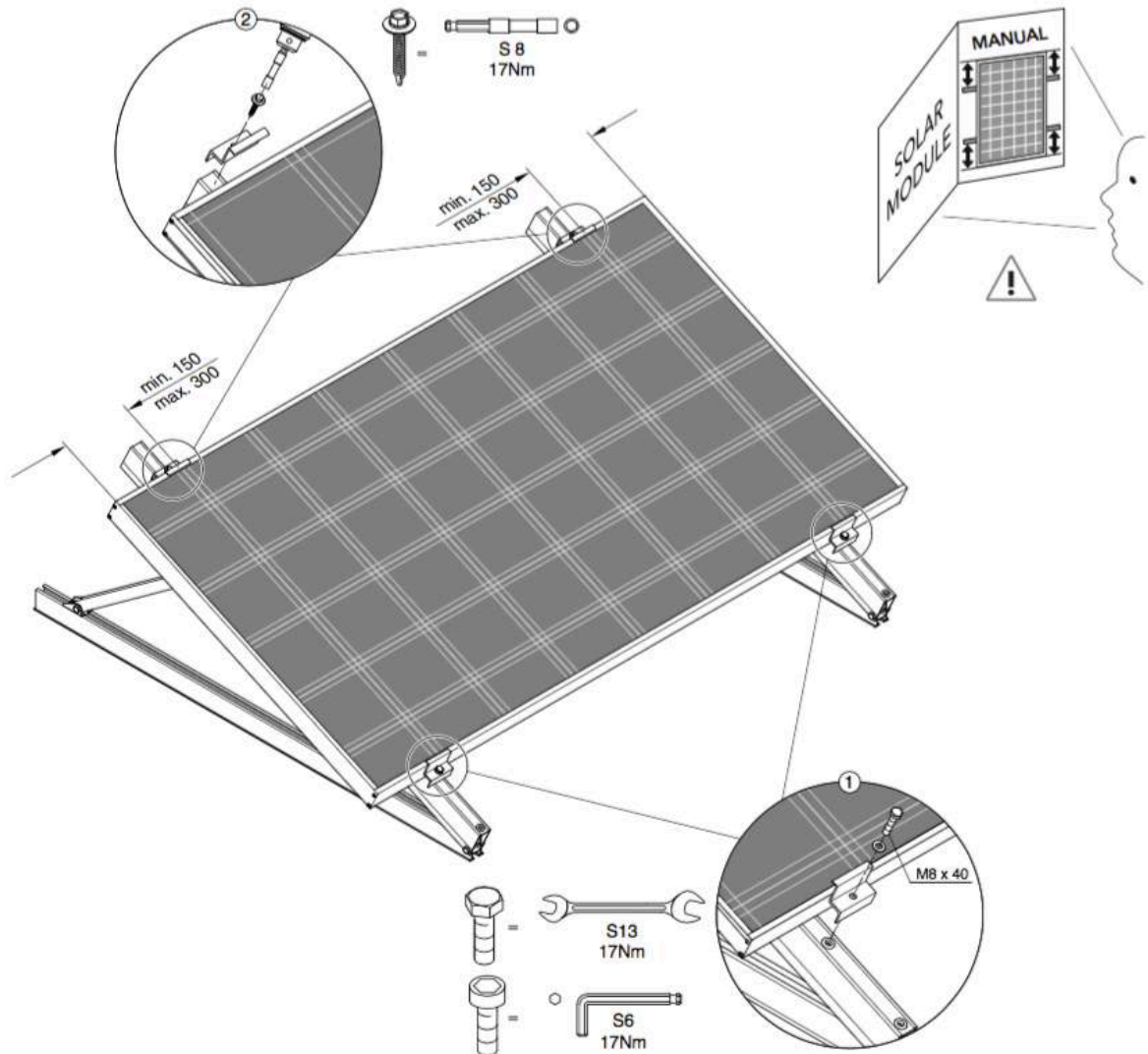

- Continue this process until you have installed all the solar panels. Ensure all screws and clamps are sufficiently tightened.
- Remember to ballast your ground mount system accordingly. Please contact us if you need any further information on the amount of ballast required.

MICRO-INVERTER INSTALLATION

- Once you have completed installing the Ground Mount system, attach the Micro-Inverters to Solar Panel Frames, or Ground Mount using nuts, bolts or Z-Modules provided. You will need your Hex key and Spanner. Ensure the bolts are tightened securely.

Option 1:

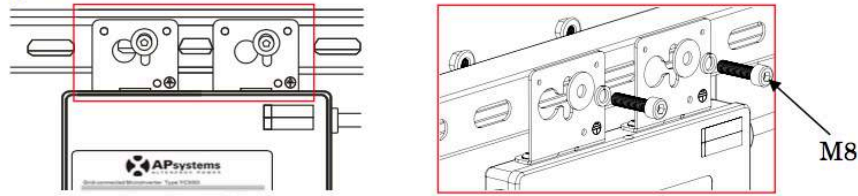

Option 2:

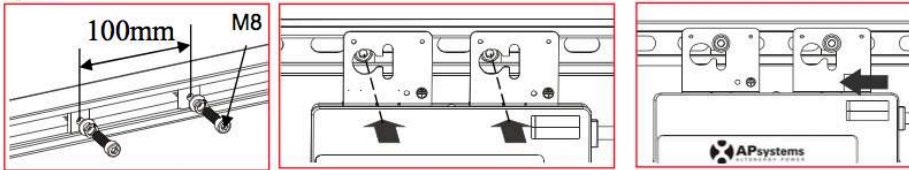

NOTE: If you are unable to bolt the inverter to the solar panel frame, use the SFS (self drilling) screws provided to affix the Micro-Inverter to the upper arm of the Ground Mount Kit. See image below for guidance.

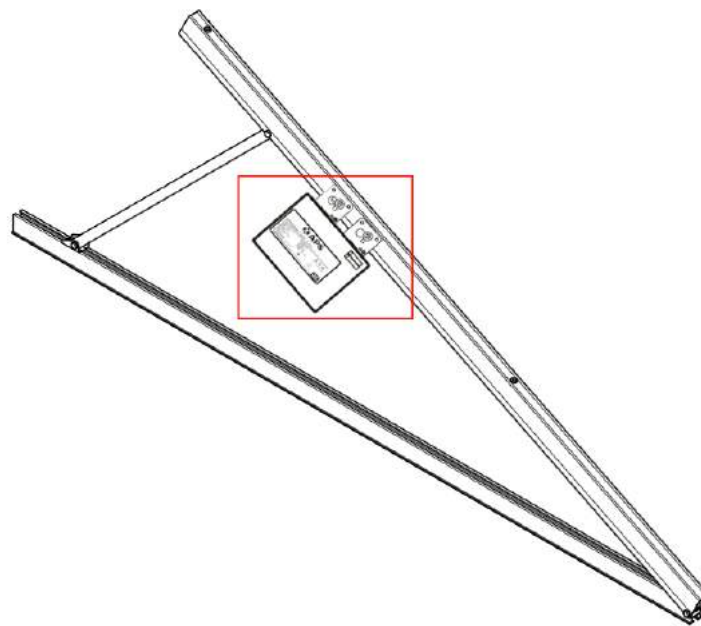

Each Micro-Inverter has serial number labels affixed. Once the micro-inverters are installed, please peel one label off each micro-inverter and stick them to the warranty card (please refer to the 'Completing Your Warranty Card' section of this installation manual for more information).

2. Connect the Micro-Inverters to the AC Bus Trunk Cable

Connect the AC connector of the Micro-Inverter to the AC Bus Trunk Cable. Do this for each Micro-Inverter in your system. Ensure a click is heard as connectors engage. Ensure that all connections are properly closed.

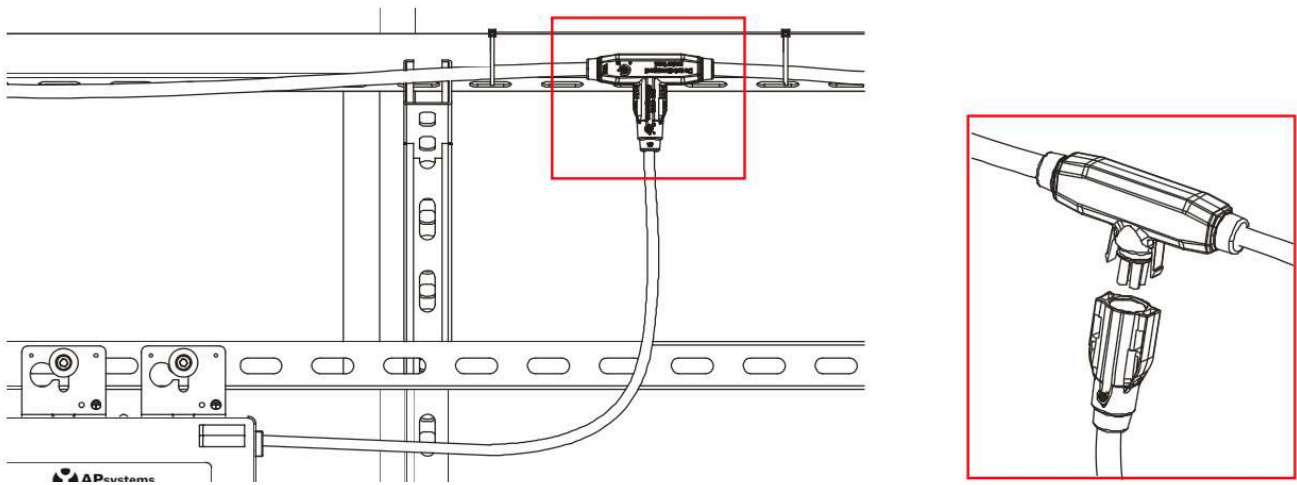

WARNING: Do NOT exceed a maximum of (5) five Micro-Inverters in an AC branch circuit when using the Plug-In Solar System.

Cover any unused connectors on the AC Bus Trunk Cable to protect the connectors. Ensure a click is heard as connectors engage. Ensure that all connections are properly closed.

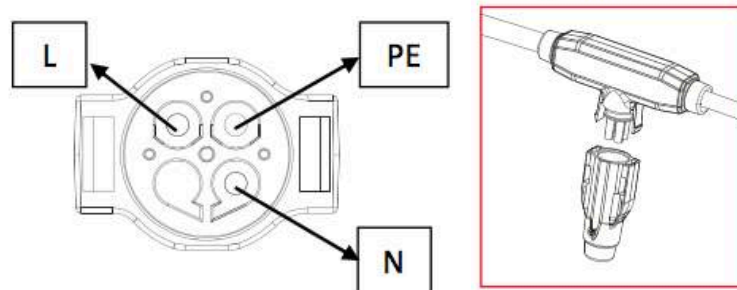

3. Install Protective End Cap onto the AC Bus Trunk Cable

a. Strip AC Bus Trunk Cable

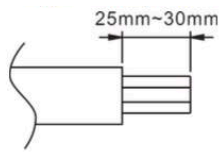

b. Insert the cable end into the seal.

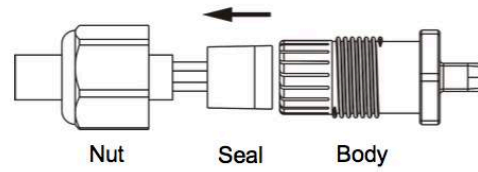

c. Insert the wires into the cable clamps.

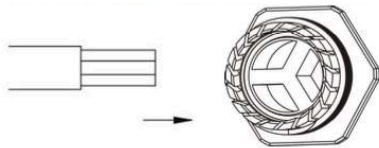

d. Rotate the nut with 3.3N·m until the latching mechanism meets the base.

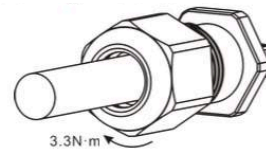

4. Connect Micro Inverters to Solar Panels (PV Modules)

Connect each Solar Panel to the Micro-Inverter DC cables to feed PV power into the Micro inverter, following the polarity direction marked on each Micro inverter. Ensure a click is heard as connectors engage.

When plugging in the DC cables, the Micro-Inverter should immediately blink green three times. This will happen as soon as the cables are plugged in and will show that the Micro-Inverter is functioning correctly. This entire check function will start and end within 5 seconds of plugging in the unit, so pay careful attention to these lights when connecting the DC cables.

WARNING: Ensure that all AC and DC wiring is correct. Ensure that none of the AC and DC wires are pinched or damaged. Ensure that all connections are properly closed.

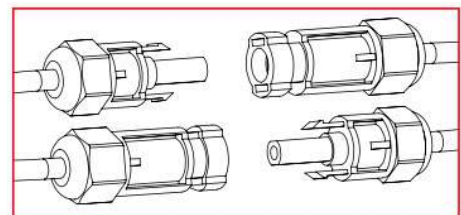
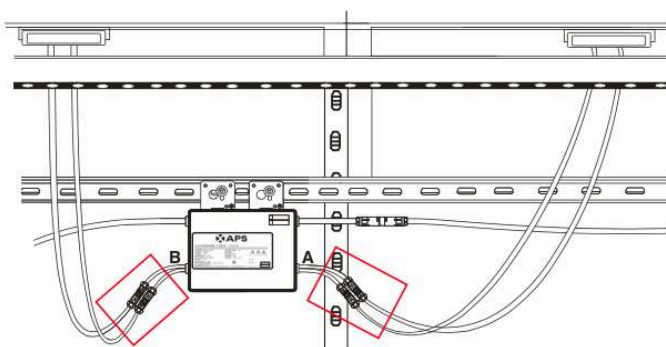

WARNING: If you are installing an odd number of Solar panels, ensure you use the MC4 sealing caps provided with your kit to seal the exposed MC4 connectors on the Micro-Inverter.



5. If you need to extend the length of AC Bus Trunk Cable, we can supply extra lengths on request. If you provide your own cable please be sure to use the correct cable wire size (AWG) depending on distance of the last Micro-Inverter to the connection point and the number of Micro-Inverters in the branch, as shown in the table below. Please be aware, the longer the cable run, the greater the power loss.

External Wire size(AWG)	Number of Micro-Inverters in branch							
	2	3	4	5	6	7	8	9
	<i>Maximum External cable length (ft)</i>							
12	370.7	237.1	167.9	124.3	93.6	70.2	51.4	35.7
10	593.1	379.4	268.6	198.9	149.7	112.3	82.3	57.1
8	926.8	592.9	419.6	310.7	233.9	175.5	128.6	89.3
6	1482.8	948.6	671.4	497.1	374.3	280.8	205.7	142.9

Follow the instructions outlined below to connect the APS AC Bus Trunk Cable to your extension cable, using a connection box, or similar (supplied upon request).

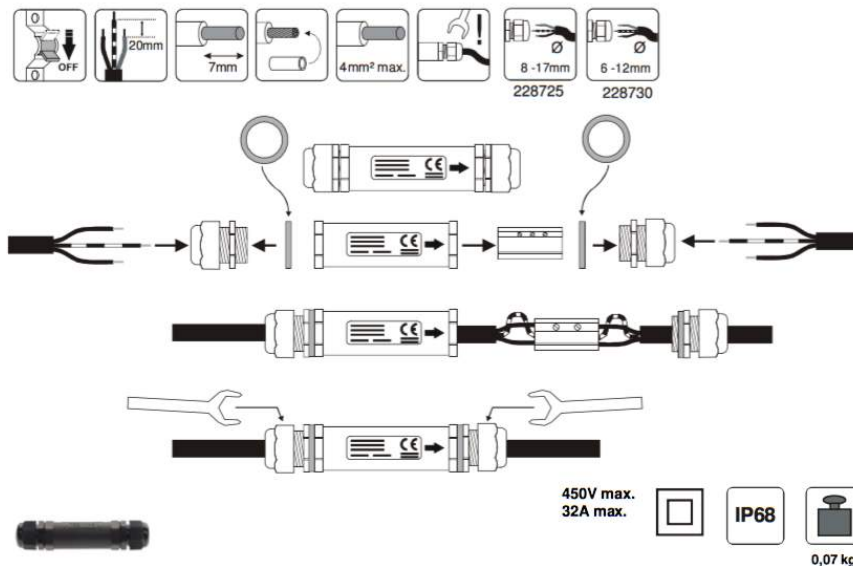

WIRING THE SOLAR TO THE EXISTING MAINS CIRCUIT

IMPORTANT SAFETY INFORMATION – FOR YOUR PROTECTION

Before installation please read these instructions carefully and use the Plug-In Solar Connection Unit in accordance with these safety wiring instructions.

In older houses, you may find a variety of old fuse boxes where the mains supply comes in. You may also have wiring and fittings of an older style. These may not be up to the standard required today. If this is the case, have it all checked and tested by a professional electrician BEFORE carrying out any work on it. Some old installations may now be dangerous.

Electricity is dangerous. Always disconnect from mains supply before any inspection or repair to equipment. Safety must always be given top priority. Do not allow children to tamper with electrical devices.

ALWAYS FOLLOW THE IET WIRING REGULATIONS.

You must NOT install the Plug-In Solar Connection Unit in the following locations as set out by Part P:

- (a) within a room containing a bath or shower, the space surrounding a bath tap or shower head, where the space extends —
 - (i) vertically from the finished floor level to —
 - (aa) a height of 2.25 metres; or
 - (bb) the position of the shower head where it is attached to a wall or ceiling at a point higher than 2.25 metres from that level; and
 - (ii) horizontally —
 - (aa) where there is a bath tub or shower tray, from the edge of the bathtub or shower tray to a distance of 0.6 metres; or
 - (bb) where there is no bath tub or shower tray, from the centre point of the shower head where it is attached to the wall or ceiling to a distance of 1.2 metres; or
- (b) a room containing a swimming pool or sauna heater.

As an additional precaution, wear rubber-soled shoes. This will provide a measure of insulation between you and the ground!

IF YOU ARE NOT ABSOLUTELY CERTAIN ABOUT ANY ASPECT OF ELECTRICAL WORK, SEEK PROFESSIONAL ADVICE

1.1. Switch off the power and remove the fuse for the relevant circuit before carrying out any work, or inspecting, either it, or the appliances connected to it. Never inspect, or carry out work on, any part of the system with the power on. Make sure that power cannot be inadvertently restored by someone else.

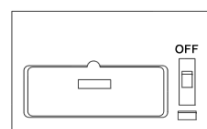
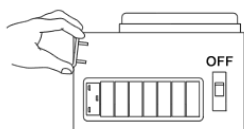

1.2. Use a voltage tester to check the power to the wires or connections are off before touching them.

1.3. Once the power is disconnected, wire the Plug-In Solar Connection Unit using the following instructions.

Wire Identification (if in doubt consult a qualified electrician)
EARTH – Green and Yellow Sleeving
LIVE – Red or Brown
NEUTRAL – Blue or Black

- a) If using the Plug-In Solar Connection Unit to replace an old socket (or similar), note the cable connections and wire up the Plug-In Solar Connection Unit the same way as the replaced item, with earthing as stated in these instructions.
- b) Route the cable through the appropriate entry point of the mounting box (this is usually at the rear).
- c) Cables should be prepared so sufficient conductor length reaches the terminals. Strip the ends of the individual conductors so that an adequate length enters the terminals.
- d) Carefully arrange the wiring to lie along the edges of the product or box, keeping the central area clear.
- e) Wire the Plug-In Solar Connection Unit using the following diagram (a larger version can be found in Appendix 1):

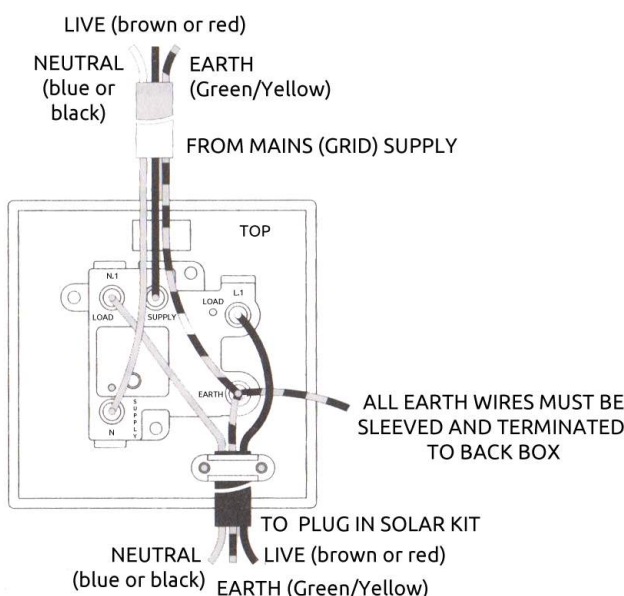

- f) When connecting the Plug-In Solar Connection Unit ensure that only the bare end of the wire enters the terminal, and no bare wires are visible. Always tighten the terminal screws, but don't over tighten. An earth connection should always be made between the mounting box earth terminal and the fused connection unit terminal. If the earth wire is bare, it must be sleeved with appropriate green/yellow sleeving.
- g) If you are in any doubt about connecting this product consult a qualified electrician.

1.4. Wiring insulation tests should be completed to avoid misleading instrument readings and possible internal damage to the unit. Check your work thoroughly before restoring power to the circuit. If you are not certain, seek professional advice.

1.5. Once power has been restored, your Plug-In Solar kit will be feeding FREE electricity into your mains circuit.

ISOLATION/ISOLATOR REQUIREMENTS

Under G83/2 requirements, it must be possible to isolate a Plug-In Solar kit from the from the DNO's Distribution System, using a Double Pole Isolator. This is the function of the Plug-In Solar Connection Unit.

The Plug-In Solar Connection Unit, is a double pole Switched Fused Connection Unit, that adheres to British Standard BS1363-4, and offers on load isolation from the grid.

G83/2 regulations also state that the Plug-In Solar Connection Unit is lockable in the OFF position only. This ensures isolation under maintenance. The Fuse carrier of the Plug-In Solar Connection Unit can be locked open (the OFF position), as per the image below, in order to meet this requirement (padlock not provided).



PLACING WARNING LABELS

When installing a Plug-In Solar kit you must place labelling at the **Plug-In Solar Connection Unit, Existing Consumer Unit** and at all points of isolation between the **Plug-In Solar Connection Unit** and the **Solar Panels** within your premises. This is to indicate the presence of a Small Scale Embedded Generation installation (SSEG). The labelling should be fixed in place to ensure that it remains legible and secure for the lifetime of the installation. The following labels must be used and have been provided with your Plug-In Solar kit.

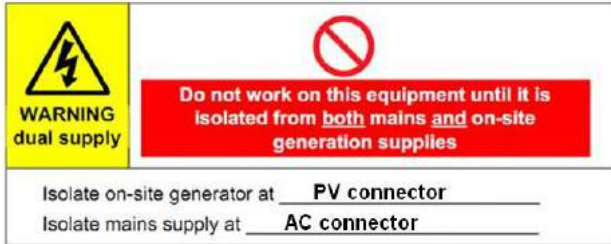

Dual supply labelling should be placed at the Plug-In Solar Connection Unit between the PV system and Existing Consumer Unit to indicate the presence of on-site generation and indicating the position of the main A.C switch disconnector.

An APS Inverter should be labelled stating "Inverter - isolate A.C. and D.C. before carrying out work". The Micro-Inverters also have this warning label as standard.

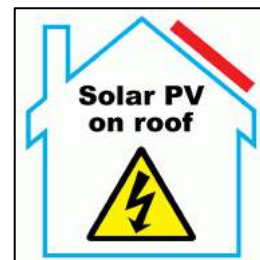
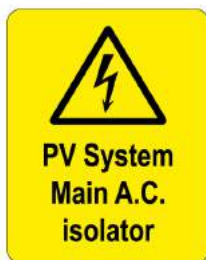

An AC isolator Label should be placed next to the Plug-In Solar Connection Unit and all other AC switches/disconnects (if applicable). ON and OFF positions should be clearly labelled.

To ensure the Fire and Rescue Service are aware that Solar is installed on the roof the following sign shall also be fitted next to the existing consumer unit in the building. You do not need this label for Ground Mount systems.

In addition to this safety labelling, you must also display an electrical schematic diagram next to the existing consumer unit in the property. You will have been provided with an electrical schematic diagram relevant to your kit, but can see an example in Appendix 3. Please note the diagram in Appendix 3 is non-prescriptive and is for illustrative purposes only.

INSPECTING AND TESTING YOUR PLUG-IN SOLAR INSTALLATION

As part of the G83/2 on-site commissioning tests you shall carry out a functional check of the loss of mains protection, for example by removing the supply to the Plug-In Solar kit during operation and checking that the Plug-In Solar Connection Unit operates to disconnect the Plug-In Solar Kit from the DNO's Distribution System.

In the UK the installation of a Plug-In Solar Kit is considered non-notifiable electrical work under Part P of the Building Regulations 2013, as it is an alteration to an existing installation (the mains grid).

“Regulation 12(6A) sets out electrical installation work that is notifiable. All other electrical installation work is not notifiable – namely additions and alterations to existing installations outside special locations, and replacements, repairs and maintenance anywhere.”

Installation of a non-notifiable Plug-In Solar kit should still be designed, installed, inspected, tested and certificated in accordance with **BS 7671**.

For more information on how to do this, you can find a copy of Part P building regulations here: http://www.planningportal.gov.uk/uploads/br/BR_PDF_AD_P_2013.pdf

COMMISSIONING YOUR PLUG-IN SOLAR INSTALLATION

Once you have installed, inspected and tested your Plug-In Solar kit, it is a requirement that you complete and return a G83/2 SSEG Installation Commissioning Confirmation Form to your District Network Operator (DNO) within 28 days.

Distribution Network Operators (DNOs) own and operate the distribution network of towers and cables that bring electricity from the national transmission network to homes and businesses. They don't sell electricity to consumers, this is done by the electricity suppliers. Informing the DNO of your installation allows them to manage the grid more effectively.

There are 9 different DNO's across the UK, so you must make sure you submit your form to the correct DNO in your area. You can find your DNO by entering your postcode using this website: <https://www.ssepd.co.uk/Whoismynetworkoperator/>

Once you have identified your DNO you must download a G83/2 SSEG Installation Commissioning Confirmation Form from their website (or request that they e-mail one to you).

Completing G83/2 SSEG Installation Commissioning Confirmation Form

An example G83/2 Commissioning Confirmation Form can be found in Appendix 2 of this Installation Manual. Please note G83/2 forms differ between DNO's, this is an example only.

The G83/2 SSEG Installation Commissioning Confirmation Form is relatively self-explanatory, however there are a number of sections that you must complete correctly:

SSEG Installation Address Details Section

	Sussex	Found on your electricity bill
Post Code	AB12 3CD	
MPAN	17 123456789000	

S	01	123	456
	12	1234 5678	345

A Meter Point Administration Number, also (MPAN), is a 21-digit reference used in the UK to uniquely identify electricity supply points. You must correctly fill in your own MPAN in this section of the form.

Your MPAN can be found on your electricity bill and often looks like the image on the left.

SSEG Details Section

Capacities	phase 1 in kW	phase 2 in kW	phase 3 in kW	Type test ref only for new installations	Primary energy source. Eg Wind, Solar PV, Hydro, Gas CHP.
New/Existing	1kW				Solar PV
New/Existing					
New/Existing					

Within the SSEG Details section of the form, fill in the details of your installation. The capacity will be the size of the Plug-In Solar kit you purchased, i.e. 1kW. The Primary Energy Source must always be filled as 'Solar PV'. If you have any existing SSEG's (e.g. wind/solar) you must also declare these here.

SSEG Installer Details Section

Name	Mr No. Body	Signed		Date	1/1/2016
On behalf of Installer	Mr No. Body				
Accreditation / Qualification	N/A (Self Installed)				
Installer address	1 The Road, One Place Sussex				
Post code	AB12 3CD				
Contact person	Mr No. Body				
Telephone number	01234 567891				
Email address	info@info.co.uk				

As Plug-In Solar kits are DIY, self installed solar systems you should complete this section as the installer. In the Accreditation/Qualification section you should fill this in as 'N/A (Self-Installed)', unless you have an appropriate accreditation. This section of the form also needs to be signed.

Along with the completed G83/2 SSEG Installation Commissioning Confirmation Form, you must also supply the DNO with the following:

1. An electrical schematic diagram for your installation (A relevant electrical schematic diagram will be provided with your Plug-In Solar Kit). An example can be seen in Appendix 3.
2. A copy of the G83/2 SSEG Test Report Certificate for the Micro-Inverters (This can be found in Appendix 7)
3. A photograph of your existing electricity meter (be sure to include the make and model of the meter)

Email/Fax/Post the information above to your DNO using the contact supplied on the Commissioning Form. Do not send it to Plug-In Solar, we cannot apply to the DNO on your behalf.

When the DNO has received your form and it has been processed, you will get a confirmation email/letter to say it has been accepted.

Notifying the DNO of changes to a Plug-In Solar kit

If during the lifetime of the Plug-In Solar kit it is necessary to replace a major component of the Plug-In Solar kit, it is only necessary to notify the DNO if the operating characteristics of the Plug-In Solar kit or the Plug-In Solar Connection Unit have been altered when compared against the unit that was originally commissioned.

Notifying the DNO of the decommissioning of a Plug-In Solar kit

In the event that a Plug-In Solar kit is to be decommissioned and will no longer operate as a source of electrical energy in parallel with the DNO's Distribution System, you must notify the DNO by completing a G83/2 SSEG Decommissioning Confirmation Form. Please contact your DNO for a copy of this form.

COMPLETING YOUR WARRANTY CARD

In order to fulfill the requirements of the manufacturers, you must complete Warranty Cards for the Micro-Inverters, which provide system information and installation maps to APS. A Warranty Card can be found in Appendix 6.

Each Micro-Inverter has serial number labels affixed. Once the inverters are installed, please peel one of the labels off each Micro-Inverter and affix them to the warranty card.

Fill in the warranty card with each of the labels according to the layout on the roof/ground.

For APS Micro-Inverters, fill the warranty card and email to APS at emasupport@altenergy-power.com.

If you have a purchased an online monitoring system, please refer to the User Manual provided with this guide for detailed instructions on how to install it correctly, and use these installation maps to set it up.

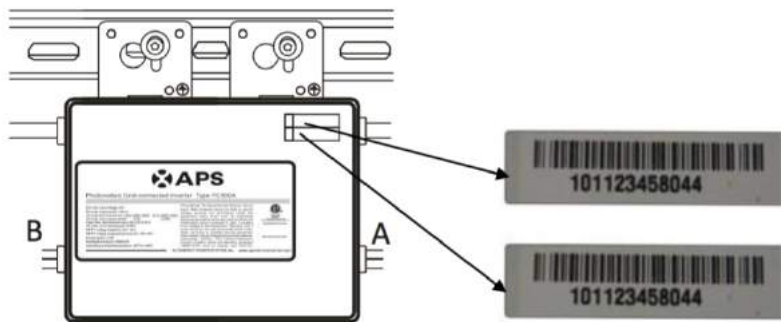

1	2	3	4	5	6	7	8	9	10	11	12
B	A									B	A

An arrow points from the labels in column 1 and 2 towards the label in column 11.

APPENDIX 1. PLUG-IN SOLAR CONNECTION UNIT – WIRING DIAGRAM

ALWAYS FOLLOW THE IET WIRING REGULATIONS

IF YOU ARE NOT ABSOLUTELY CERTAIN ABOUT ANY ASPECT OF ELECTRICAL WORK,
SEEK PROFESSIONAL ADVICE

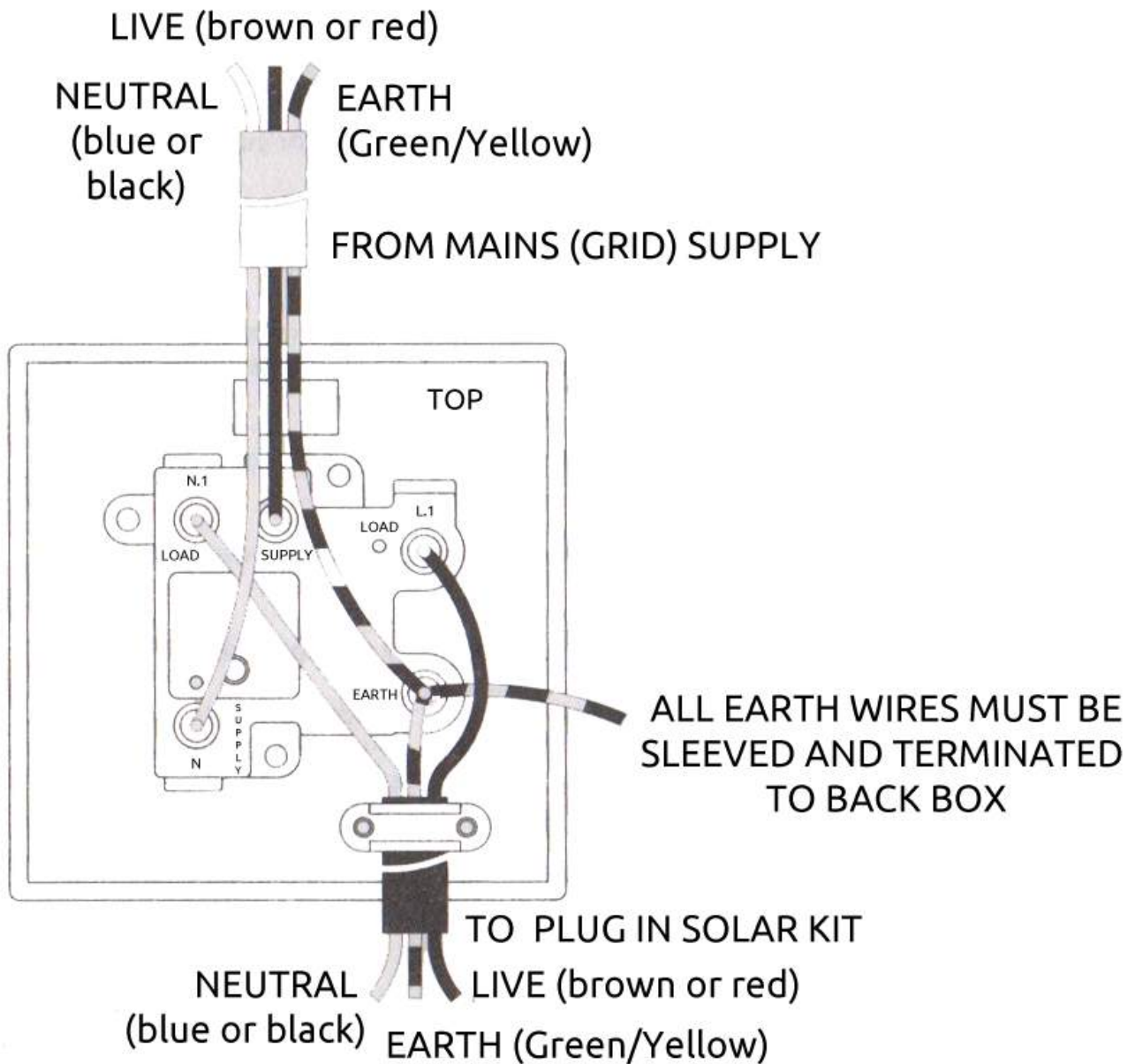

APPENDIX 2. EXAMPLE G83/2 COMMISSIONING CONFIRMATION FORM

Please note, G83/2 SSEG Installation Commissioning Confirmation Forms differ between DNO's and this may not look like the form you receive. This is non-prescriptive and is for illustrative purposes only.

SSEG installation address details						
Name of Customer at Site	Mr No. Body					
Customer contact telephone	01234 567891					
Site address	1 The Road, One Place Sussex					
Post Code	AB12 3CD					
MPAN	17 123456789000					
SSEG owner if different from above						
Name and Contact Address	As Above					
Including Post Code						
Contact telephone number	As Above					
SSEG Details						
Note only technologies with Type Tested equipment can be installed under G83/2.						
Capacities	phase 1 in kW	phase 2 in kW	phase 3 in kW	Type test ref only for new installations	Primary energy source. Eg Wind, Solar PV, Hydro, Gas CHP.	
New/ Existing	1kW				Solar PV	
New/Existing						
New/Existing						
New/Existing						
The Maximum aggregate capacity of SSEGs installed in a single customer's installation under G83/2 is 3.68kW per phase at 230V AC.						
Identify above new SSEG installations and existing installations at the site which have not been de-commissioned as of the date of this declaration. Use a separate line for new and existing installations and for different Primary Energy sources above. For installations above 3.68kW per phase the separate G59 process applies and the DNO needs to be consulted before any installation is undertaken. Use ph 1 column for single phase supply						
I confirm that the new SSEGs noted above has/ have been installed and commissioned to comply with the requirements of G83/2 as required by The Distribution Code. I enclose a copy of the circuit diagram which has been left on site at the customers incoming meter location.						
Name	Mr No. Body	Signed		Date	1/1/2016	
On behalf of Installer	Mr No. Body					
Accreditation / Qualification	N/A (Self Installed)					
Installer address	1 The Road, One Place Sussex					
Post code	AB12 3CD					
Contact person	Mr No. Body					
Telephone number	01234 567891					
Email address	info@info.co.uk					

APPENDIX 3. EXAMPLE ELECTRICAL SCHEMATIC DIAGRAM

This is non-prescriptive and is for illustrative purposes only.

Electrical Schematic Diagram for 1kW (1000W) Domestic Solar PV System

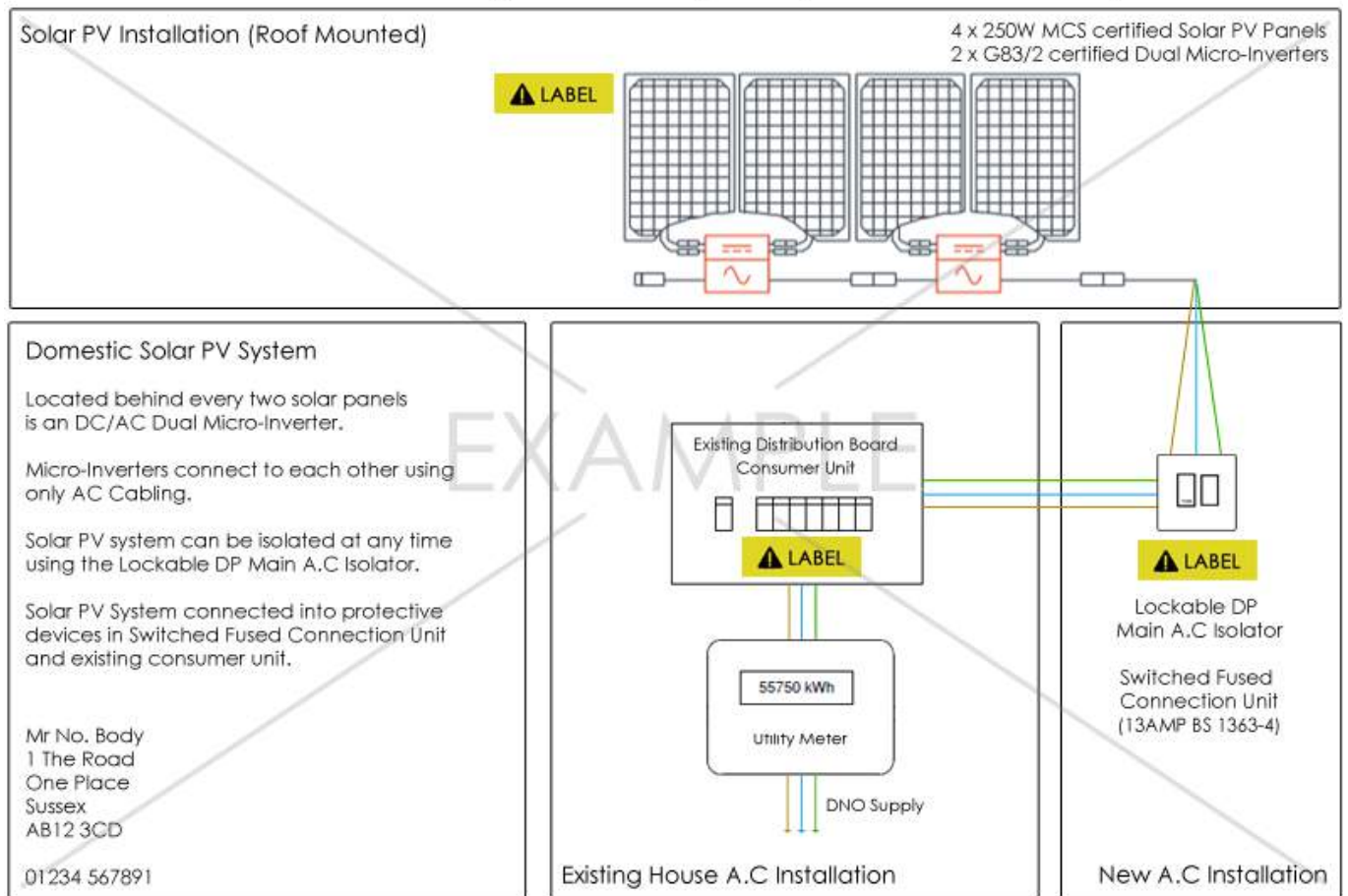

APPENDIX 4. TROUBLESHOOTING APS DUAL MICRO-INVERTERS

Status Indications and Error Reporting

Startup LED

When DC power is first applied to the Micro-Inverter: Three short green blinks indicate a successful Micro-Inverter startup.

Operation LED

Flashing Slow Green (10s gap) - Producing power and communicating with ECU

Flashing Fast Green (2s gap) – Producing power and not communicating with ECU

Flashing Red – Not producing power

GFDI Error

A solid red LED indicates the Micro-Inverter has detected a ground fault (GFDI) error in the PV system. Unless the GFDI error has been cleared, the LED will remain red and the ECU will keep reporting the fault.

After the ground fault error is fixed, follow the instructions in the *ECU Installation and Operation Manual* to clear this GFDI error reporting.

Non-Operating Micro-Inverters

1. To troubleshoot a non-operating APS Micro-Inverter, follow the steps below in order:
2. Check the connection to the utility grid. Verify utility power is present at the inverter in question by removing AC, then DC power. **Never disconnect the DC wires while the Micro-Inverter is producing power.** Re-connect the DC module connectors and watch for three short green LED flashes.
3. Check the AC branch circuit interconnection between all the Micro-Inverters. Verify each micro-inverter is energised by the utility grid as described in the previous step.
4. Make sure that any AC breakers are functioning properly and are closed.
5. Check the DC connections between the Micro-Inverter and the PV module.
6. If the problem persists, please contact APS Energy customer support on 0031-10-2582670 or email info@altenergy-power.com. **DO NOT** attempt to repair the APS Micro-Inverter. If troubleshooting methods fail, please return the Micro-Inverter to your distributor for replacement.

Warranty Regulations and Liability

Altenergy Power System (APS) products are designed to withstand normal operating conditions when used for its originally intended purpose in compliance with the APS User Manual supplied with the originally shipped system. The APS limited warranty ("Limited Warranty") covers defects in workmanship and materials of the APS products ("Defective Product"). APS provides both default warranty and extended warranty as follows which starts from the shipping date.

Default/ Extended (year)	China	Others
YC500	5/5	10/25
YC250	5/5	10/25
YC1000-3	5/5	10/25
ECU	1/1	1/1
Accessories	1/1	1/1
Note: Extra fees apply to extended warranty.		

During the Warranty Period, APS will, at its option, repair or replace the Defective Product free of charge, provided APS, through inspection, establishes the existence of a defect that is covered by the Limited Warranty. APS will, at its option, use new and/or reconditioned parts in repairing or replacing the Defective Product. APS reserves the right to use parts or products of original or improved design in the repair or replacement of Defective Product. If APS repairs or replaces a Defective Product, the Limited Warranty continues on the repaired or replacement product for the remainder of the original Warranty Period or ninety (90) days from the date of APS's return shipment of the repaired or replacement product, whichever is later.

The Limited Warranty covers both parts and labor necessary to repair the Defective Product, but does not include labor costs related to un-installing the Defective Product or re-installing the repaired or replacement product. The Limited Warranty also covers the costs of shipping repaired or replacement product from APS, via a non-expedited freight carrier selected by APS.

The Limited Warranty does not cover, and APS will not be responsible for, shipping damage or damage caused by mishandling by the freight carrier and any such damage is the responsibility of the freight carrier.

To obtain repair or replacement service under this Limited Warranty, the customer must comply with the following policy and procedure:

- All Defective Product must be returned with a Return Merchandise Authorization (RMA) number which customer must request from APS. Before requesting the RMA, however, the customer should contact an APS technical support representative to evaluate and troubleshoot the problem while the APS product is in the field, since many problems can be solved in the field.
- If in-field troubleshooting does not solve the problem, customer may request the RMA number, with following information:

- Proof-of-purchase of the Defective Product in the form of (1) the dated purchase receipt from the original purchase of the product at point of sale to the end user, or (2) the dated dealer invoice or purchase receipt showing original equipment manufacturer (OEM) status, or (3) the dated invoice or purchase receipt showing the product exchanged under warranty.
- Model number of the Defective Product
- Serial number of the Defective Product
- Detailed description of the defect
- Shipping address for return of the repaired or replacement product
- All Defective Product authorized for return must be returned in the original shipping container or other packaging that is equally protective of the product.
- The returned Defective Product must not have been disassembled or modified without the prior written APS authorization.

The Limited Warranty does not apply to, and APS will not be responsible for, any defect in or damage to any APS product: (1) "Warranty card" is not returned to APS; (2) that has been misused, neglected, tampered with, altered, or otherwise damaged, either internally or externally; (3) worn out appearance, including discolor and scratch; (4) the defective has no impact on the electricity generation, including LED failure; (5) that has been improperly installed, operated, handled or used, including use under conditions for which the product was not designed, use in an unsuitable environment, or use in a manner contrary to the APS User Manual or applicable laws or regulations; (6) that has been subjected to fire, water, generalized corrosion, biological infestations, or input voltage that creates operating conditions beyond the maximum or minimum limits listed in the APS product specifications, including high input voltage from generators or lightning strikes; (7) that has been subjected to incidental or consequential damage caused by defects of other components of the solar system; or (8) if the original identification markings (including trademark or serial number) of such product have been defaced, altered, or removed; (9) changed the owner, but isn't assigned. The Limited Warranty does not cover costs related to the removal, installation or troubleshooting of the customer's electrical systems. The Limited Warranty does not extend beyond the original cost of the APS product.

THE LIMITED WARRANTY IS THE SOLE AND EXCLUSIVE WARRANTY GIVEN BY APS AND, WHERE PERMITTED BY LAW, IS MADE EXPRESSLY IN LIEU OF ALL OTHER WARRANTIES, EXPRESS OR IMPLIED, STATUTORY OR OTHERWISE, INCLUDING, WITHOUT LIMITATION, WARRANTIES OF TITLE, QUALITY, MERCHANTABILITY, FITNESS FOR A PARTICULAR PURPOSE OR NON-INFRINGEMENT OR WARRANTIES AS TO THE ACCURACY, SUFFICIENCY OR SUITABILITY OF ANY TECHNICAL OR OTHER INFORMATION PROVIDED IN MANUALS OR OTHER DOCUMENTATION. IN NO EVENT WILL APS BE LIABLE FOR ANY SPECIAL, DIRECT, INDIRECT, INCIDENTAL OR CONSEQUENTIAL DAMAGES, LOSSES, COSTS OR EXPENSES HOWEVER ARISING, WHETHER IN CONTRACTOR TORT, INCLUDING WITHOUT LIMITATION ANY ECONOMIC LOSSES OF ANY KIND, ANY LOSS OR DAMAGE TO PROPERTY, OR ANY PERSONAL INJURY.

To the extent any implied warranties are required under applicable law to apply to the APS products, such implied warranties shall be limited in duration to the Warranty Period, to the extent permitted by applicable law. Some states and provinces do not allow limitations or exclusions on implied warranties or on the duration of an implied warranty or on the limitation or exclusion of incidental or consequential

damages, so the above limitation(s) or exclusion(s) may not apply. This Limited Warranty gives the customer specific legal rights, and the customer may have other rights that may vary from province to province.

**ALTENERGY POWER SYSTEM INC**Http: www.apsmicroinverter.comEmail: info@altenergy-power.com**APS USA**

Add: 19925 Stevens Creek Blvd, Suite 100, Cupertino, CA 95014

Tel: 01 (408)-973-7888

Washington Office

Add: 1015 Hostmark St., Suite 104, Poulsbo, WA 98370

Tel: 01-206-855-5100

APS Australia

Add: 6/11-17 Banks Street, Mays Hill, NSW 2145

Tel:+ (02) 9633 3478

APS China

Add: Rm. B403 No.188, Tomson Center, Zhangyang Road, Pudong, Shanghai 200120, China

Tel: +86-21-3392-8205



APS Microinverter & Energy Communication Unit Warranty Card

The APS Installation Map is a diagram of the physical location of each microinverter in your PV installation. Each APS microinverter has a removable serial number label located on the mounting plate. Peel the label and affix it to the respective location on the APS installation map.

Installation Map Template

1	2	3	4	5	6	7	8	9	10	11	12	13	14	15	16	17	18	19	20	21	22

To register your APS microinverter, please mail this warranty registration card to: emasupport@altenergy-power.com

Certificate of Conformity

On the basis of the tests undertaken, the sample(s) of the below product have been found to comply with the requirements of the referenced specifications at the time the tests were carried out.

Applicant Name & Address	: Altenergy Power System Inc. No.1, Yatai Road, Jiaxing 314050 P.R.China
Product(s) Tested	: Grid-connected Microinverter
Ratings and principal characteristics	: See Annex to Test Verification of Conformity
Model(s)	: YC500A, YC500I
Brand name	: 
Relevant Standard(s)/Specification(s)	: Engineering Recommendation G83 Issue 2 (December 2012) Recommendations For The Connection Of Type Tested Small-Scale Embedded Generators (Up To 16A Per Phase) In Parallel With Low-Voltage Distribution Systems
Certificate Issuing Office Name & Address	: Intertek Testing Services Shanghai Limited Building No. 86, 1198 Qinzhou Road (North), Caohejing Development Zone, Shanghai 200233, China
Date of Test(s)	: 01 Sep 2014 – 11 Sep 2014
Certificate/Report Number(s)	: 140401919SHA-A / 140401919SHA-001

NOTE : This Certificate is part of the full test report(s) and should be read in conjunction with it.

This Certificate is for the exclusive use of Intertek's Client and is provided pursuant to the agreement between Intertek and its Client. Intertek's responsibility and liability are limited to the terms and conditions of the agreement. Intertek assumes no liability to any party, other than to the Client in accordance with the agreement, for any loss, expense or damage occasioned by the use of this Certificate. Only the Client is authorized to copy or distribute this Certificate. Any use of the Intertek name or one of its marks for the sale or advertisement of the tested material, product or service must first be approved in writing by Intertek. The observations and test results referenced from this Certificate are relevant only to the sample tested. This Certificate by itself does not imply that the material, product, or service is or has ever been under an Intertek certification program.

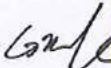
Signature

Name: Grady Ye
Position: Assistant Manager
Date: 15 Sep 2014



Limited Warranty for PV Modules

Warranty Terms 2015

Perlight Solar Co., Ltd. (“Perlight”) warrants its Modules’ performance according to this warranty. The following family products apply to this Warranty:

Intenergy brand Mono-crystalline modules:

INE-xxxM-72 pcs 6" (where xxx= 245W - 320W in increment of 5 Watts)
INE-xxxM-60 pcs 6" (where xxx= 220W - 270W in increment of 5 Watts)
INE-xxxM-54 pcs 6" (where xxx= 185W - 240W in increment of 5 Watts)
INE-xxxMB-72 pcs 6" (where xxx= 245W - 320W in increment of 5 Watts)
INE-xxxMB-60 pcs 6" (where xxx= 220W - 270W in increment of 5 Watts)
INE-xxxMB-54 pcs 6" (where xxx= 185W - 240W in increment of 5 Watts)
INE-xxxM-96 pcs 5" (where xxx= 230W - 280W in increment of 5 Watts)
INE-xxxM-72 pcs 5" (where xxx= 160W - 210W in increment of 5 Watts)
INE-xxxM-36 pcs 5" (where xxx= 80W - 105W in increment of 5 Watts)
INE-xxxMB-96 pcs 5" (where xxx= 230W - 280W in increment of 5 Watts)
INE-xxxMB-72 pcs 5" (where xxx= 160W - 210W in increment of 5 Watts)
INE-xxxMB-36 pcs 5" (where xxx= 80W - 105W in increment of 5 Watts)

Intenergy brand Poly-crystalline modules:

INE-xxxP-72 pcs 6" (where xxx= 235W - 320W in increment of 5 Watts)
INE-xxxP-60 pcs 6" (where xxx= 190W - 265W in increment of 5 Watts)
INE-xxxP-54 pcs 6" (where xxx= 180W - 240W in increment of 5 Watts)

1. Limited Product Warranty – Twelve Years Repair, Replacement or Refund Remedy

Perlight Solar Co., Ltd. (Perlight Solar) warrants its Photovoltaic Solar Modules (MODULES), including factory-assembled DC connectors and cables, if any, to be free from defect in materials and workmanship under normal application, installation, use and service conditions. If MODULES fail to conform to this warranty, during the period ending Twelve (12) years from the date of sale as shown in the invoice to the first consumer customer of the Perlight Solar product (CUSTOMER), Perlight Solar will, at its option, either repair or replace the product, or refund the purchase price as paid by the CUSTOMER. The repair or replacement or refund remedy shall be the sole and exclusive remedy provided under the “Limited Product Warranty” and shall not extend beyond the Twelve (12) years period set forth herein. This “Limited Product Warranty” does not warrant a specific power output, which shall be exclusively covered under clause 2 hereinafter (“Limited Peak Power Warranty”).

2. Limited Peak Power Warranty - Limited Remedy

➤ **12 years**

If, within a period of twelve (12) years from the date shown in the invoice to the CUSTOMER any MODULE(s) exhibits a power output less than 90 % of the minimum “Peak Power at STC”(standard test conditions) as specified at the date of invoice in Perlight Solar’s Product Information Sheet. The actual power output of the module shall be determined for verification using Standard Testing Conditions only. The actual power output measurement is either carried out by a Perlight Solar facility or by a Perlight Solar recognized 3rd party testing institute. Testing equipment tolerances will be applied to all actual power output measurements. And such loss in power is determined by Perlight, at its sole discretion, to be due to the Modules’ defects in material or workmanship attributed to Perlight, and Perlight will, at its sole option and discretion, either (1) make up such loss in power by providing to Customer additional Modules or provide an appropriate residual market value of the product(s) as compensation; or (2) repair or replace the defective Modules including free shipping to the place supplied by Perlight.

➤ **25 years**

If, within a period of twelve (25) years from the date shown in the invoice to the CUSTOMER any MODULE(s) exhibits a power output less than 80 % of the minimum “Peak Power at STC”(standard test conditions) as specified at the date of invoice in Perlight Solar’s Product Information Sheet. The actual power output of the module shall be determined for verification using Standard Testing Conditions only. The actual power output measurement is either carried out by a Perlight Solar facility or by a Perlight Solar recognized 3rd party testing institute. Testing equipment tolerances will be applied to all actual power output measurements. And such loss in power is determined by Perlight, at its sole discretion, to be due to the Modules’ defects in material or workmanship attributed to Perlight, and Perlight will, at its sole option and discretion, either (1) make up such loss in power by providing to Customer additional Modules or provide an appropriate residual market value of the product(s) as compensation; or (2) repair or replace the defective Modules including free shipping to the place supplied by Perlight.

The remedies set forth in this clause 2 shall be the sole and exclusive remedies provided under the “Limited Peak Power Warranty”.

3. Exclusions and Limitations

(1) In any event, all warranty claims must be filed within the applicable warranty period.

(2) The “Limited Product Warranties” and the ”Limited Peak Power Warranties” do not apply to any MODULES which have been subjected to:

- ✧ Misuse, abuse, neglect or accident;
- ✧ Alteration, improper installation or application;
- ✧ Non-observance of Perlight Solar’ s installation and maintenance instructions;
- ✧ Repair or modifications by someone other than an approved service technician of Perlight Solar;
- ✧ Power failure surges, lightning, flood, fire, accidental breakage or other events outside Perlight Solar’s control.

(3) Both, the “Limited Product Warranties” and “Limited Peak Power Warranties” do not cover any transportation charge, customs clearance or any other costs for return of the MODULES, or for reshipment of any repaired or replaced MODULES, or costs associated with installation, removal or reinstallation of the PV-modules.

(4) Warranty claims will not be honored if the type or serial number of the MODULES have been altered, removed or made illegible.

(5) In addition, the limited warranties do not apply to any cosmetic change in appearance stemming from the normal wear and tear over time of product materials. Any color change on module or any other changes on module appearance do not represent defects, insofar as the change in appearance does not stem from defects in material and/or workmanship, and does not cause degradation of functionality of the module, which are exempt from this warranty.

4. Limitation of Warranty Scope

These “Limited Warranties for PV Modules” as set forth herein are expressly in lieu of and exclude all other express or implied warranties, including but not limited to warranties of merchantability and of fitness for particular purpose, use, or application, and all other obligations or liabilities on the part of Perlight Solar, unless such other obligations or liabilities are expressly agreed to in writing signed and approved by Perlight Solar. Perlight Solar shall have no responsibility or liability whatsoever for damage or injury to persons or property, or for other loss or injury resulting from any cause whatsoever arising out of or related to the MODULES, including, without limitation, any defects in the MODULE, or from use or installation. Under no circumstances shall Perlight Solar be liable for incidental, consequential or special damages, howsoever caused. Loss of use, loss of profits, loss of production, and loss of

revenues are specifically and without limitation excluded. Perlight Solar's aggregate liability, if any, in damages or otherwise, shall not exceed the invoice value as paid by the CUSTOMER, for the single unit of MODULE.

5. Obtaining Warranty Performance

If the CUSTOMER feels a justified claim covered by this "Limited Warranties for PV Modules", an immediate notification directly to Perlight Solar shall be filed by mailing a [registered/certified] letter in writing to the address of Perlight Solar listed hereunder, or, sending an email letter to the email account of Perlight Solar listed hereunder. Together with the notification, the CUSTOMER should enclose the evidence of the claim with the corresponding serial number of the MODULE(s) and the invoice on which the MODULES have been purchased. An invoice with clear indication of the purchase date, purchase price, module type, stamp or signature of Perlight or its distributors should also be submitted as part of the evidence.

If the Modules will be returned to Perlight for inspection, repair or replacement by Perlight, Perlight will give the Customer a Return Merchandise Authorization (RMA). However, Perlight will not accept a return of any Modules without an RMA.

6. Disputes

In case of any discrepancy in a warranty-claim, a first-class international test-institute be negotiated by both party, shall be involved to judge the claim finally. All fees and expenses shall be born by the losing party, unless otherwise awarded. The final explanation right shall be borne by Perlight Solar. The applicable law for the product manufacturing countries related legal provisions. Any Understand ambiguity, the Chinese shall prevail.

7. Various

The repair or replacement of the MODULES or the supply of additional MODULES, does not cause the beginning of new warranty terms, nor shall the original terms of this "Limited Warranty for PV-Modules" be extended. Any replaced MODULES shall become the property of Perlight Solar made for their disposal. Perlight Solar has the right to deliver another type (different in size, color, shape and/or power) in case Perlight Solar discontinued producing the replaced MODULES at the time of the claim.

8. Force Majeure

Perlight Solar shall not be responsible or liable in any way to the customer or any third-party arising from any non-performance or delay in performance of any terms and conditions of sale, including this "Limited Warranty for PV Modules", due to acts God, war, riots, strikes, warlike conditions, plague or other epidemics, fire, flood, or any other similar cause or circumstance beyond the reasonable control of such Perlight. In such cases, performance by Perlight of this Limited Warranty shall be suspended without liability for the period of delay reasonably attributable to such causes.

9. Validity

This "Limited Power Warranty for PV Modules" is valid for all MODULES dispatched between 1st January 2015 and 31st December 2015.

"Peak Power at STC" is the power in Watt peak that a PV- module generates in its Maximum Power Point. "STC" are as follows

- (a) A light spectrum of AM 1.5,
- (b) An irradiation of 1000W per m²,
- (c) A cell temperature of 25 degree centigrade at right angle irradiation. The measurements are carried out in accordance with IEC 61215 as tested at the connectors or junction box terminals – as applicable – per calibration and

testing standards of Perlight Solar valid at the date of manufacture of the PV-modules.

NOTES:

“Peak Power” is the power in watt peak that a PV-module generates in its maximum power point under STC condition. ‘STC’ are as follows: (a) light spectrum of AM 1.5, (b) an irradiation of 1,000W/m² and (c) a cell temperature of 25 degree Centigrade at right angle irradiation. The measurements are carried out in accordance with IEC61215 as tested at the junction box terminals per the calibration and testing standards of Jinko valid at the date of manufacture of the PV-Modules. Jinko’s calibration standards shall be in compliance with the standards applied by international institutions accredited for this purpose.

Perlight Solar Co., Ltd.

Address: Oufeng Road, Muyu Administration District, Wenling, Zhejiang, 317521, China

Tel: 0086-576-86477290

Fax: 0086-576-86479190

Email: service@perlight.com www.perlight.com





Certificate No: MCS BBA 0005

Technology: MCS 005 Solar Photovoltaic Modules

Products: .

Mono-crystalline photovoltaic modules

- PLM-xxx/24 (where xxx = 150W - 205W in increments of 5W)
- PLM-xxxM-72 pcs 6" (where xxx = 245W - 320W in increments of 5W)
- PLM-xxxM-60 pcs 6" (where xxx = 220W - 270W in increments of 5W)
- PLM-xxxM-54 pcs 6" (where xxx = 185W - 240W in increments of 5W)
- PLM-xxxM-36 pcs 5" (where xxx = 80W - 105W in increments of 5W)
- PLM-xxxMB-72 pcs 6" (where xxx = 245W - 320W in increments of 5W)
- PLM-xxxMB-60 pcs 6" (where xxx = 220W - 270W in increments of 5W)
- PLM-xxxMB-54 pcs 6" (where xxx = 185W - 240W in increments of 5W)
- PLM-xxxM-96 pcs 5" (where xxx = 230W - 280W in increments of 5W)
- PLM-xxxM-72 pcs 5" (where xxx = 160W - 210W in increments of 5W)
- PLM-xxxMB-96 pcs 5" (where xxx = 230W - 280W in increments of 5W)
- PLM-xxxMB-72 pcs 5" (where xxx = 160W - 210W in increments of 5W)
- PLM-xxxMB-36 pcs 5" (where xxx = 80W - 105W in increments of 5W)

- INE-xxxM-72 pcs 6" (where xxx = 245W - 320W in increments of 5 Watts)
- INE-xxxM-60 pcs 6" (where xxx = 220W - 270W in increments of 5 Watts)
- INE-xxxM-54 pcs 6" (where xxx = 185W - 240W in increments of 5 Watts)
- INE-xxxMB-72 pcs 6" (where xxx = 245W - 320W in increments of 5 Watts)
- INE-xxxMB-60 pcs 6" (where xxx = 220W - 270W in increments of 5 Watts)
- INE-xxxMB-54 pcs 6" (where xxx = 185W - 240W in increments of 5 Watts)
- INE-xxxM-96 pcs 5" (where xxx = 230W - 280W in increments of 5 Watts)
- INE-xxxM-72 pcs 5" (where xxx = 160W - 210W in increments of 5 Watts)
- INE-xxxM-36 pcs 5" (where xxx = 80W - 105W in increments of 5 Watts)
- INE-xxxMB-96 pcs 5" (where xxx = 230W - 280W in increments of 5 Watts)
- INE-xxxMB-72 pcs 5" (where xxx = 160W - 210W in increments of 5 Watts)
- INE-xxxMB-36 pcs 5" (where xxx = 80W - 105W in increments of 5 Watts)

Continued



Poly-crystalline photovoltaic modules

PLM- Pxxx/36, (where xxx = 205W - 250W in increments of 5W)

PLM-xxxP-72 pcs 6" (where xxx = 235W - 320W in increments of 5W)

PLM-xxxP-60 pcs 6" (where xxx = 190W - 265W in increments of 5W)

PLM-xxxP-54 pcs 6" (where xxx = 180W - 240W in increments of 5W)

INE-xxxP-72 pcs 6" (where xxx = 235W - 320W in increments of 5 Watts)

INE-xxxP-60 pcs 6" (where xxx = 190W - 265W in increments of 5 Watts)

INE-xxxP-54 pcs 6" (where xxx = 180W - 240W in increments of 5 Watts)

Perlight Solar Co., Ltd
Oufeng Road, Muyu Administration Area
Zeguo Town, Wenling City
Zhejiang Province
317521
P,R.China

The BBA (British Board of Agrément) has issued this Microgeneration Certification Scheme (MCS) Certificate to the company and products named above, in recognition of the products's compliance with the MCS Scheme Requirements for the technology named above.

On behalf of the British Board of Agrément

Date of Fourth issue: 24 July 2014

Claire Curtis-Thomas
Chief Executive

The BBA is a UKAS accredited certification body — Number 113. The schedule of the current scope of accreditation for product certification is available in pdf format via the UKAS link on the BBA website at www.bbacerts.co.uk

Readers are advised to check the validity and latest issue number of this MCS Certificate by either referring to the BBA website or contacting the BBA direct.

Functional Warranty TRIC Racking Systems



Material and Workmanship

Wagner & Co guarantees functionality and durability of the TRIC racking system components as well as that they are free of material and production faults, provided they were installed, used and maintained according to the prescribed conditions and instructions.

Wagner & Co grants this warranty for a period of ten years after the date of sale to a retailer or installer.

Entitlements

The value of potential warranty entitlements is limited to the net purchase price of the products.

In a warranty case Wagner & Co will decide on either replacing or repairing the faulty product or reimbursing the purchase price.

There are no additional liabilities or warranty entitlements. In particular Wagner & Co is not liable for:

- Costs of new installations and extensions,
- Appraisal and testing costs,
- Packaging and shipping costs as well as
- Foregone profits

All liability is excluded for damage caused by severe weather or force majeure.

Limitations and Conditions

Potential warranty entitlements are limited to the prescribed period of this guarantee. In order to secure potential warranty entitlements the following conditions apply:

- The mounting racks were thoroughly installed observing the installation manuals, layout plans and structural calculations.
- For the design and installation of the system the codes, regulations and technical standards applicable at the time of the installation have been observed.

- No damages occurred during transportation, storage and operation.

Any warranty entitlements granted will not extend the overall guarantee period of 10 years. Replaced parts or products will become property of Wagner & Co.

Warranty Claim

For any potential warranty claim you immediately have to contact the retailer or installer where you obtained the racking systems. The retailer/installer will explain the required further steps.

You have to make your warranty claim in writing and send it in together with a proof of purchase and a description of the fault.

Otherwise our current general business conditions apply.

Cölbe, Germany, February 2012